

VERNIER CALIPER

Best Vcal

METROLOGY®



Precision. unique. innovation.

Best Vcal

VERNIER CALIPER

PRECISION UNIQUE INNOVATION

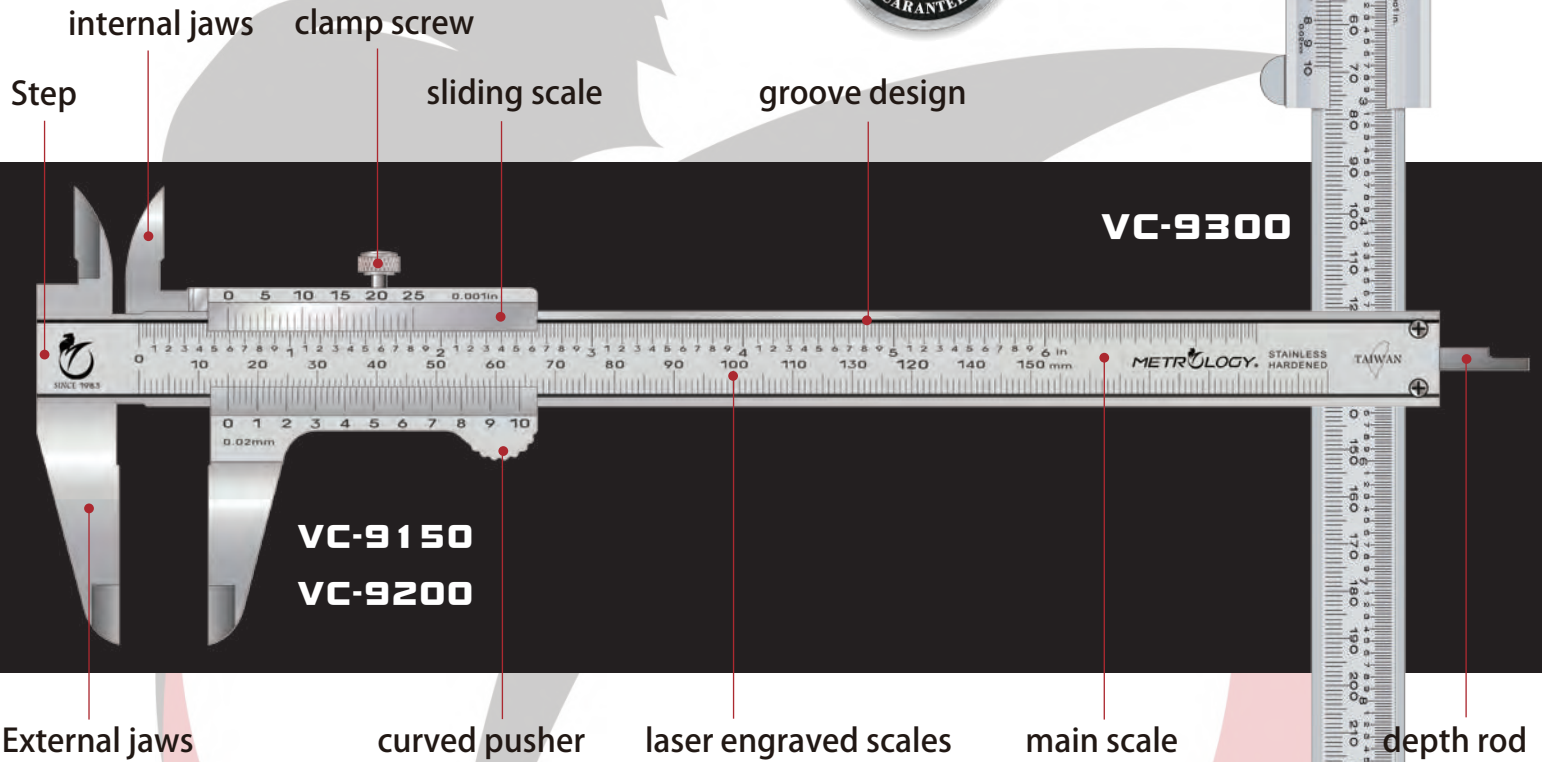

FEATURE

- 4 measuring utilities: external, internal, depth, and steps.
- Hardened stainless steel hardness HRC48-52 and close type sliding scale structure design.
- Solid structural design with precision machining, chrome plating surface, laser engraved scale, guarantee wear resistance.
- Ergonomic design curved pusher, external and internal jaws for easy to use and safety.
- Unique, innovative groove-design of main scale, for eliminating dust and grease, reduce sliding friction resistance.

Model No.	Measuring Range	Graduation	Accuracy (MPE)
VC-9150	0-150mm/6"		0.02mm/0.0010"
VC-9200	0-200mm/8"	0.02mm/0.001"	0.03mm/0.0010"
VC-9300	0-300mm/12"		0.04mm/0.0015"

Remark : VC-9300 Without groove design MPE : Max Permissible Errors